

C17 UPGRADES

DELAVAL™ C17 TURBOCHARGERS

The C17 Turbocharger has a newly developed impeller wheel for enhanced compressor performance over its flow range. New diffuser designs are also available that align peak performance to specific applications. Older impeller designs are also now available fully milled from forging for increased strength for harsh running environments.

C17 COMPRESSOR STAGE UPGRADE

Benefits

- › Higher efficiency levels
- › Increased operating ranges
- › Increased exhaust waste gate margin for similar operating points
- › Milled construction with increased strength
- › Can be used in engine emissions reduction projects that require a radial turbine inlet

Upgrade Summary

- › New modern impeller design with purely radial exit
- › New optimized diffuser design
- › Newly designed compressor inlet with air foil like struts to maximize efficiency

Interchangeability

The new designs are strictly internal to the turbocharger, providing the same footprint for connection as the old designs. No additional piping modifications are required.

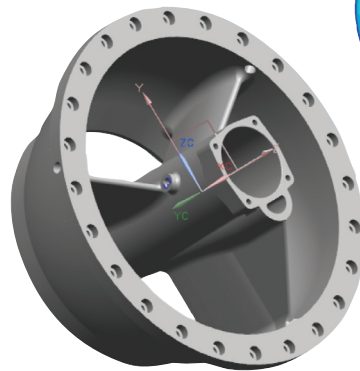
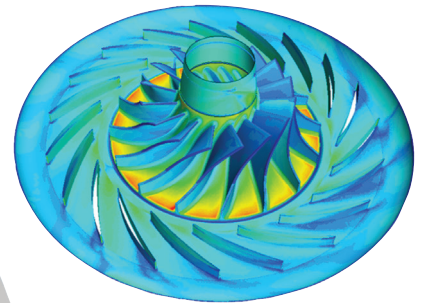
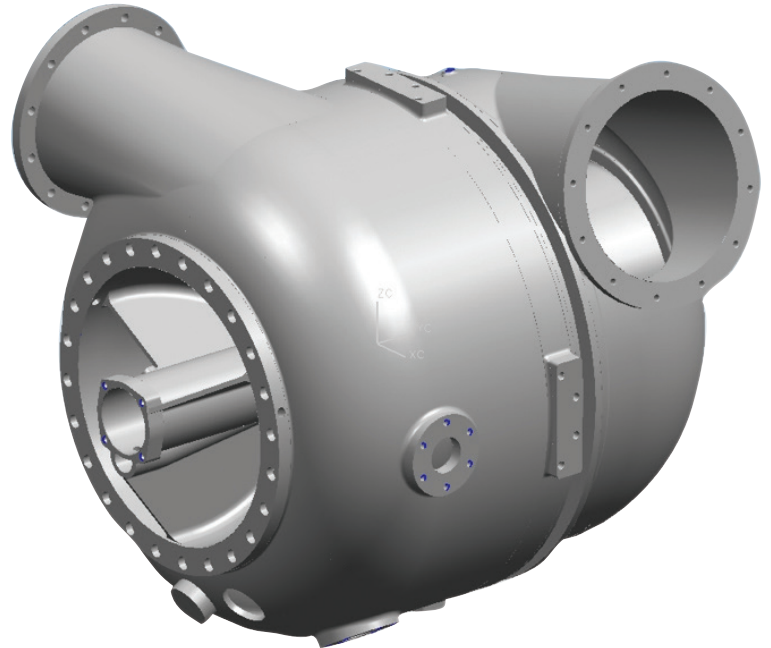

LEGENDS DON'T STOP. WE MAKE SURE OF IT.™

CALL +1-844-RECIP-43 (INTERNATIONAL: +1-713-354-1299)
24/7 TECH SUPPORT: SUPPORT@COOPERSERVICES.COM
COOPERSERVICES.COM

