

## CFA – COUPLE-FREE COMPRESSOR

Speed – 1,800 RPM, Max Power – 580 hp, Total Rod Load – 27,000 lbs

Cooper's couple-free crankshaft configuration provides low mechanical vibrations that allow lower fatigue stresses and higher reliability. Additionally, this allows

lower packaging costs and easier installation. The CFA compressor is a compact design with small foot print; it is ideal for portable skids and CNG applications.

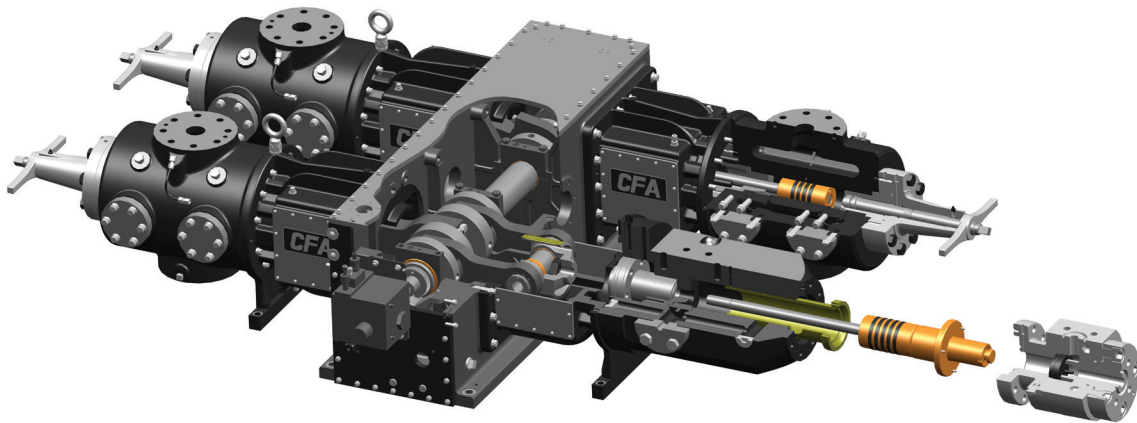

### Compressor features

**Type** – Opposing throws exactly opposite each other (common centerline), yielding lower mechanical vibrations and higher reliability.

**Frame** – Rugged, high-strength frame made from cast iron, with standard type A crosshead guides.

**Crankshaft** – Made from forged, heat-treated SAE 4140 steel designed for strength and durability.

**Connecting rods** – Forged-steel connecting rods, wide and narrow rods precision machined for interchangeability.

**Crossheads** – Single-piece, ductile-iron babbitted crossheads with bronze bushing and floating pins. Crosshead pins have oil passages to provide pressure lubrication.

**Compressor lubrication** – Lube system includes a gear-driven pump, system relief valve, crankcase strainer, spin-on type full-flow oil filter, filler/breather and plate style oil cooler.

**Cylinders** – A wide range of double-acting and tandem cylinders, MAWP up to 5,800 psi.

**Piston/piston rods** – Standard piston rods are heat-treated, SAE 4140 steel. Piston could be single or multi piece, designed for high load capacity.

**Valves** – Steel valve seats and guards, and non-metallic valve plates are standard. Springs, lift and plates are tailored specifically to your application.

**Cylinder lubrication** – Plunger-type, force-fed lubricator utilizes a divider block distribution system, a cycle indicator and a DNFT no-flow shutdown switch.

**Standard testing** – Standard compressor mechanical no-load spin test and hydrotesting of all cylinders and heads.

**Standard accessories** – Specialized tools, where applicable, are included in the toolbox.

**LEGENDS DON'T STOP. WE MAKE SURE OF IT.™**

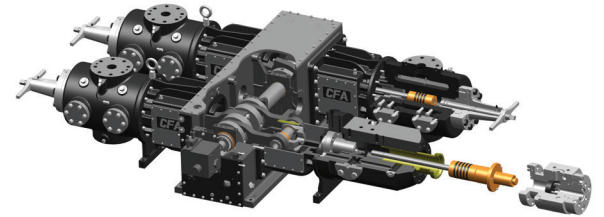

## Compressor Technical Specification

	CFA31	CFA32	CFA34
No. of cylinder throws	1	2	4
Max RPM	1,800		
Max power (hp)	145	290	580
(kW)	108	216	433
Stroke (in / mm)	3 / 76		
Main bearing diameter (in / mm)	3.125 / 79		
Piston rod diameter (in / mm)	1.125 / 29		
Combined <sup>1</sup> rod loads (lbs / kN)			
Tension	13,500 / 60		
Compression	13,500 / 60		
Total	27,000 / 120		
Frame weight (lbs)	1,200	1,200	2,000
(kg)	540	540	907

<sup>1</sup>Combined rod load = gas load + inertia load

## Reciprocating Compression Frame Lineup

Frame horsepower and combined compression rod load at max RPM

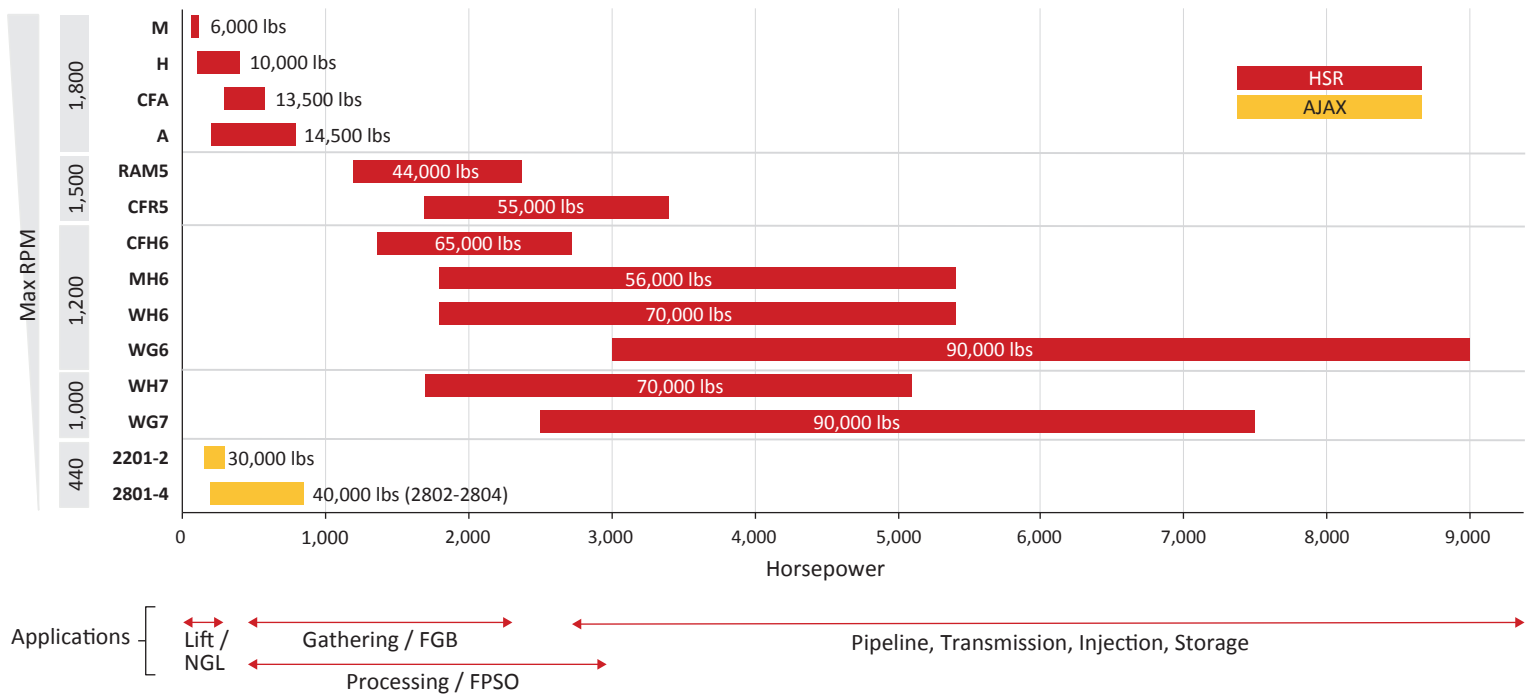

**LEGENDS DON'T STOP. WE MAKE SURE OF IT.™**

CALL +1-844-RECIP-43 (INTERNATIONAL: +1-713-354-1299)  
 24/7 TECH SUPPORT: SUPPORT@COOPERSERVICES.COM  
 COOPERSERVICES.COM

