

WG COMPRESSOR

Speed – 1,000 & 1,200 RPM, Max Power – 9,000 hp, Total Rod Load – 180,000 lbs

Cooper's WG is the largest and strongest of our high-speed reciprocating compressors. It shares an industry reputation for proven reliability. It is offered in both 6 in. stroke at 1,200 RPM speed and 7 in. stroke at 1,000

RPM speed configurations. With a full line of versatile cylinders – lined, unlined, air-cooled, water-cooled, lubricated or oil-free – the WG has the flexibility to meet the requirements of a wide variety of applications.

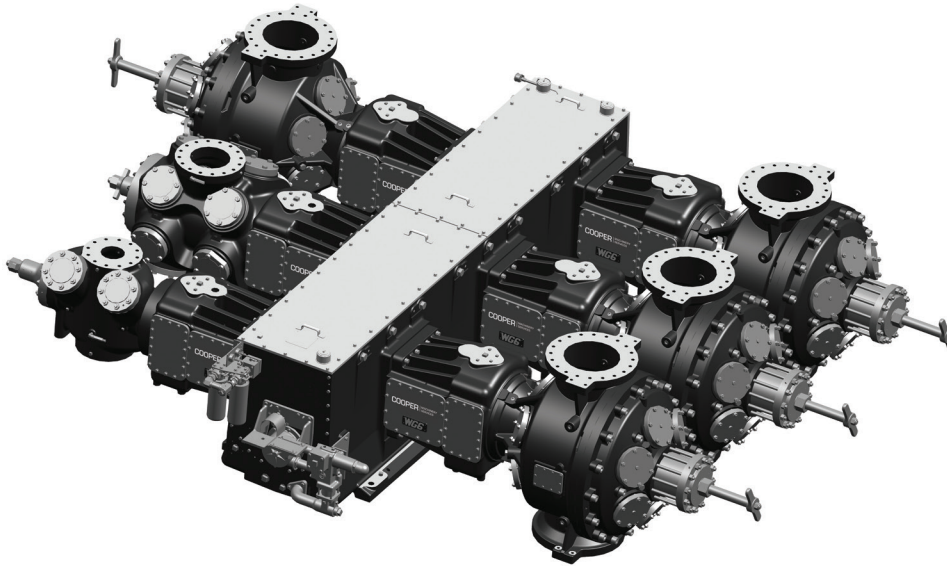

Compressor Features

Type – Balanced opposed for a smooth-operating and easy-to-service design. Engineered for reliability and low maintenance.

Frame – Rugged, high-strength frame made from cast iron with reinforced alloy steel tie bar. Standard type B crosshead guides.

Crankshaft – Made from forged, heat-treated SAE 4140 steel designed for strength and durability.

Connecting rods – Forged-steel connecting rods, rifle-drilled for forced lubrication and shot peened for additional fatigue resistance.

Crossheads – Single-piece ductile iron crossheads with replaceable trimetal shoes, bronze bushing and floating pins.

Compressor lubrication – Lubrication system includes gear-driven pump and spin-on 10-micron oil filter for easy servicing.

Cylinders – A wide range of air- and water-cooled, FlexFlow lined and unlined cylinders are available, MAWP up to 11,000 psi.

Piston/piston rods – Standard piston rods are heat-treated, SAE 4140 steel. Piston could be single or multi piece, designed for high load capacity.

Valves – Steel valve seats and guards, and non-metallic valve plates are standard. Springs, lift and plates are tailored specifically to your application.

Cylinder lubrication – Plunger type force-fed lubricator utilizes a divider block distribution system, a cycle indicator and a DNFT no-flow shutdown switch.

Standard testing – Standard compressor mechanical no-load spin test and hydrotesting of all cylinders and heads.

Standard accessories – Specialized tools, where applicable, are included in the toolbox.

LEGENDS DON'T STOP. WE MAKE SURE OF IT.™

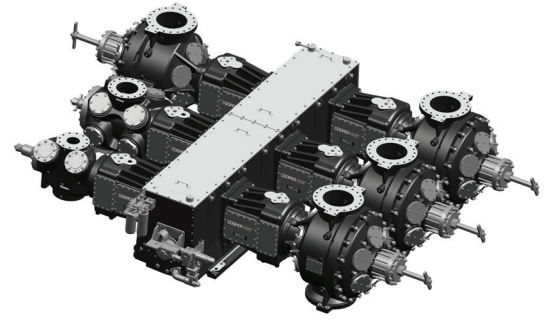

Compressor Technical Specification

	WG62	WG64	WG66	WG72	WG74	WG76
No. of cylinder throws	2	4	6	2	4	6
Max RPM	1,200			1,000		
Max power (hp)	3,000	6,000	9,000	2,500	5,000	7,500
(kW)	2,237	4,474	6,711	1,864	3,728	5,593
Stroke (in / mm)	6 / 152			7 / 178		
Main bearing diameter (in / mm)	8 / 203			8 / 203		
Piston rod diameter (in / mm)	2.75 / 70			2.75 / 70		
Combined ¹ rod loads (lbs / kN)						
Tension	90,000 / 400			90,000 / 400		
Compression	90,000 / 400			90,000 / 400		
Total	180,000 / 801			180,000 / 801		
Frame weight (lbs)	11,500	21,500	31,500	11,500	21,500	31,500
(kg)	5,216	9,752	14,288	5,216	9,752	14,288

¹Combined rod load = gas load + inertial load

Reciprocating Compression Frame Lineup

Frame horsepower and combined compression rod load at max RPM

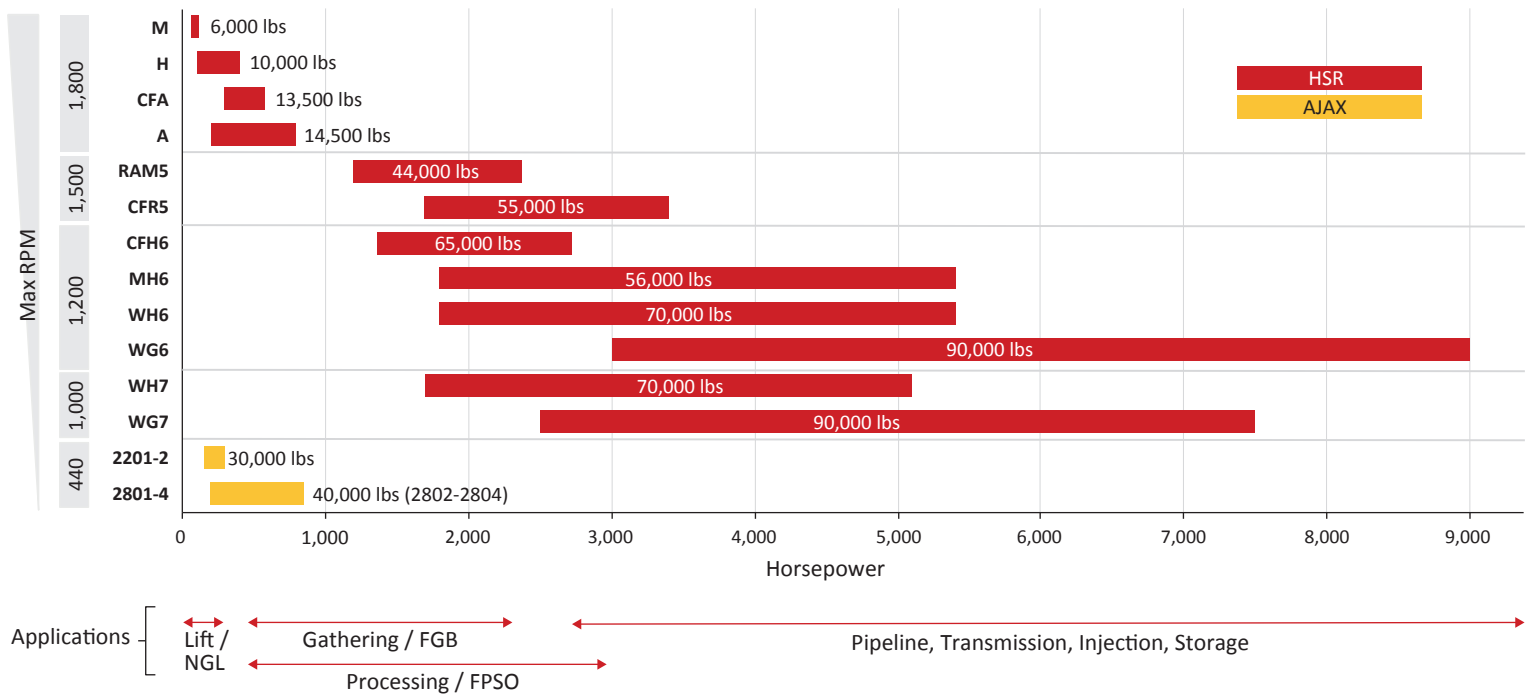

LEGENDS DON'T STOP. WE MAKE SURE OF IT.™

CALL +1-844-RECIP-43 (INTERNATIONAL: +1-713-354-1299)
 24/7 TECH SUPPORT: SUPPORT@COOPERSERVICES.COM
 COOPERSERVICES.COM

